Mazda 4-Rotor Rotary Engine for the Le Mans 24-Hour Endurance Race

Ritsuharu Shimizu, Tomoo Tadokoro, Toru Nakanishi, and Junichi Funamoto

Mazda Motor Corp

Mazda 4-Rotor Rotary Engine for the Le Mans 24-Hour Endurance Race

Ritsuharu Shimizu, Tomoo Tadokoro, Toru Nakanishi, and Junichi Funamoto
Mazda Motor Corp.

ABSTRACT

The "R26B" 4-rotor rotary engine is a powerplant that brought a Mazda racing car to victory in the 1991 Le Mans 24-hour endurance race. This engine was developed to achieve high levels of power output, fuel efficiency, and reliability, as required of endurance racing engines. This paper describes the basic structure of the engine, including a 3-piece eccentric shaft that represents a major technological achievement incorporated in the engine, as well as other technological innovations employed for the enhancement of the engine's power output and reliability, and for reducing its fuel consumption. These innovations include a telescopic intake manifold system, peripheral port injection, 3-plug ignition system, 2-piece ceramic apex seal, and a cermet coating on the rubbed surfaces of the housings.

INTRODUCTION

It was in 1967 when Mazda first launched a 2-rotor engine car. Since 1968, we have been a serious participant in motor sport events to achieve engineering gains that could ensure the rotary engine's durability and reliability. The rotary engine, starting its life as a 2-rotor unit, has ever increasingly evolved at Mazda into an engine of higher level of performance, with 3-rotor and 4-rotor units added in recent years.

The 1991 Le Mans 24-hour endurance race, an event in the Sportscar World Championship series was held with two category entrants competing together. Category 1 covered naturally-aspirated cars up to 3.5-L displacement and Category 2 represented cars which were free to have any type, configuration, and layout of engine, while constrained only by a maximum of 2550 litres of gasoline available for consumption during the race. The 4-rotor engine, "R2613", was developed to meet the Category 2 regulations. A Mazda 787B (Fig. 1),

powered by an R26B engine, scored the overall victory with a sustained full-power run. This paper reviews the basic construction of this engine and the technologies developed to improve its power output, fuel consumption, and reliability.

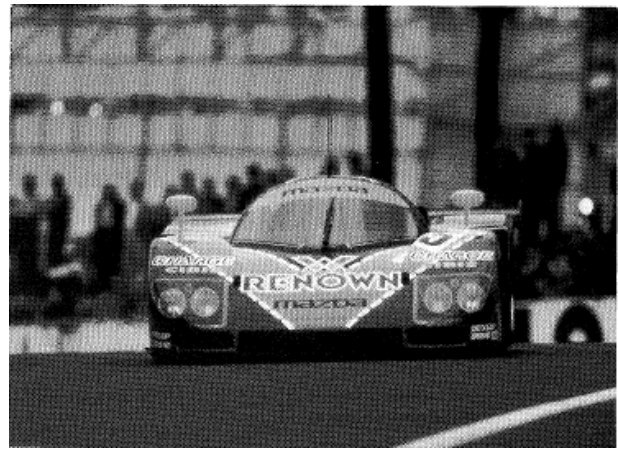

Fig. 1 Mazda 787B

OBJECTIVES OF DEVELOPMENT AND TECHNOLOGIES USED

To ensure that the R26B engine achieved simultaneous improvement of output, fuel consumption, and reliability, while meeting Category 2 regulations, the following were set as primary development objectives:

- (1) Enhancing Output Performance and Throttle Response
The main objective here was to realize a substantial increase in power output, while providing a wide torque range and a quick throttle response, thus easing driver control of the vehicle.

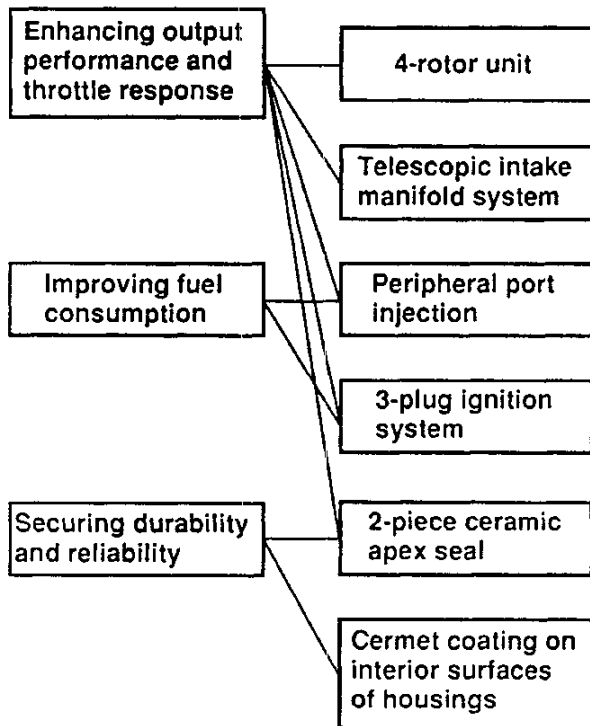

Fig. 2 Objectives of development and principal technologies

Table 1 Main data of R26B engine

Category	Type
Cylinder arrangement	4-rotor in line
Displacement (cc)	654 cc × 4-rotor
Eccentricity × generating radius × width (mm)	15 × 105 × 80
Compression ratio	10.0
Intake Porting	Peripheral Porting
Maximum output (kW/rpm)	515 kW / 9000rpm
Maximum torque (N·m/rpm)	608 N·m / 6500 rpm
Weight (kg)	180
Fuel supply system	Electronic controlled fuel injection
Induction system	Telescopic intake manifold system
Lubrication system	Dry sump
Cooling system	Water cooling
Ignition system	Electronically controlled CDI

- (2) Improving Fuel Consumption
The objectives were to reduce fuel consumption and to realize a fuel control system suitable for circuit driving, thus improving total fuel consumption.
- (3) Securing Durability and Reliability
The third target was to realize a high level of reliability that would allow the car to withstand, with some margin, a continuous 24-hour 5000-km run at full power; in other words, enduring the rigors of the Le Mans race.

The technologies developed to meet the above objectives are diagrammatically shown in Fig. 2.

ENGINE SPECIFICATIONS

Table 1 lists the specifications of the R26B engine. It is a naturally-aspirated 4-rotor unit designed to balance power output and fuel efficiency, while having other attributes, required of a racing engine such as maximum ease of installation and servicing.

(1) OUTLINE OF ENGINE

Fig. 3 is a photo of the R26B, and Fig. 4 a sectional view. The 4-rotor engine is common in trochoid configuration and unit chamber volume with Mazda's production rotary engines on which it is based. The rotor, designed for a compression ratio of 10:1, is precision-cast, using the lost wax process to reduce the mass of the rotating system.

The rotor and side housings have cermet-coated internal surfaces. The apex seal, made of ceramics, is a 2-piece type designed for enhanced reliability and gas sealing.

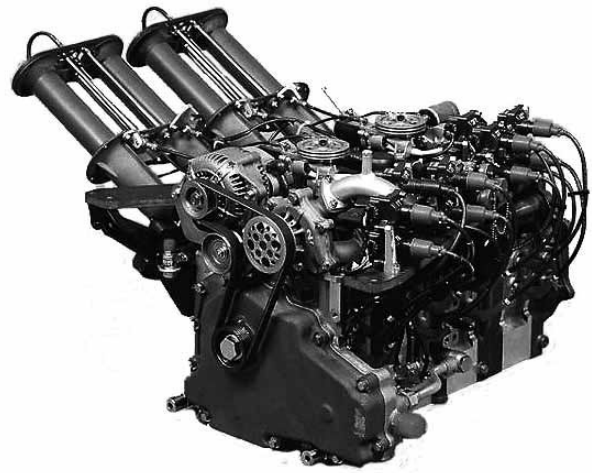

Fig. 3 Photo of the R26B

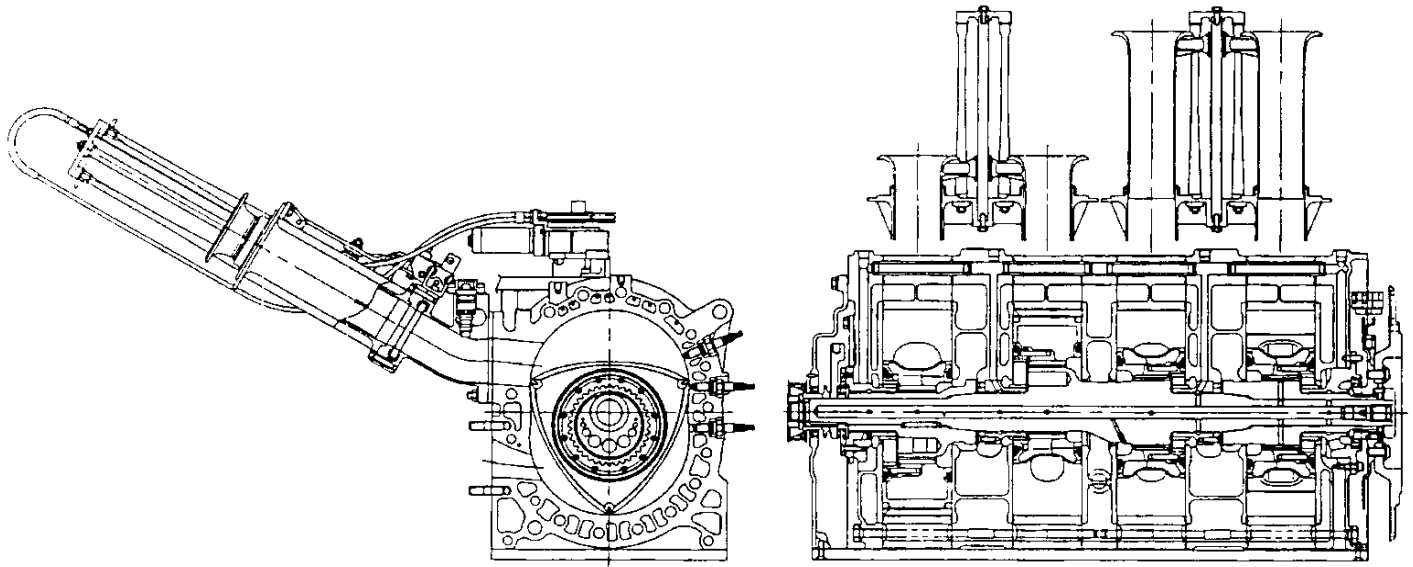

Fig. 4 Sectional view of R26B

For induction, the engine employs peripheral ports for good volumetric efficiency, with a sliding throttle valve used for low restriction in wide-open throttle (WOT) operation. Another feature is the telescopic intake manifold system (TIMS), the first of its kind ever used on a racing engine.

(2) ENGINE CONTROL SYSTEM

The engine control system used on the R26B is illustrated in Fig. 5. The main control parameters are fuel injection volume, injection timing, ignition timing, telescopic intake pipe length, number of fuel pumps, power generation, failsafe system, diagnostics, fuel consumption monitoring, and data transfer.

To measure intake air amount, the engine employs the a-N method which uses throttle opening and engine speed as parameters.

The fuel control system, in addition to controlling fuel injection, volume and timing, handles air/fuel ratio feedback. This ensures the fuel delivery to be free from the effects of external turbulence throughout the driving range, thus allowing the engine to be operated at the targeted air/fuel ratios.

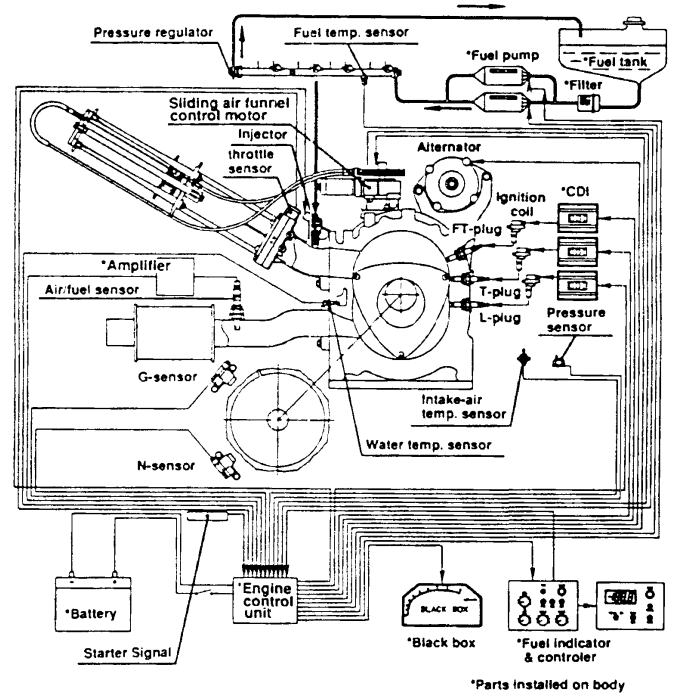

Fig. 5 Engine control system of R26B

ENGINE PERFORMANCE

The R26B engine's performance curves are shown in Fig. 6. Its maximum output is 515 kW at 9000 rpm with a peak torque of 608 Nm at 6500 rpm. By having the air-fuel ratio, fuel injection timing, and ignition timing optimized for efficiency, a minimum fuel consumption of 286 g/kWh at 6000 rpm was obtained.

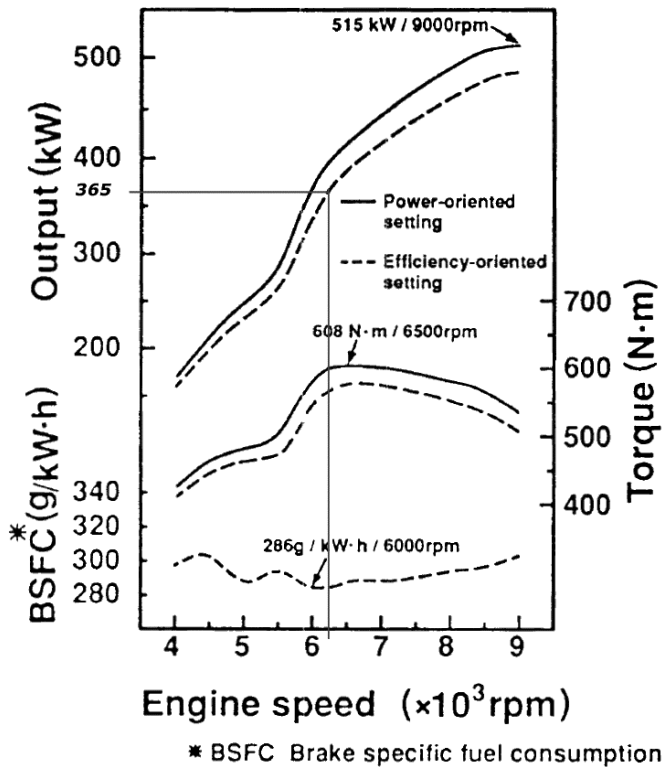

Fig. 6 Engine performance curve of R26B

TECHNOLOGIES DEVELOPED

(1) 4-ROTOR ENGINE

The most important task faced in designing a rotary engine with three or more rotors was how best to assemble the rotors in the rotor housings. Although a multirotor engine could be built by employing one of several methods, including the use of a built-up eccentric shaft via Curvic coupling, splining, etc., and a split stationary gear or split bearing, a taper coupling was developed that proved superior in reliability and integrity. This type of eccentric shaft has been in use since 1986, starting with a 3-rotor racing engine. (1) As shown in Fig. 7, the R26B's eccentric shaft comprises three pieces: a main shaft with No.2 and No.3 rotor journals, and hollow end shafts at the front and at the rear, having rotor journals for the No.1 and No.4 rotors, respectively. The hollow front and rear shafts are taper-coupled to the main shaft.

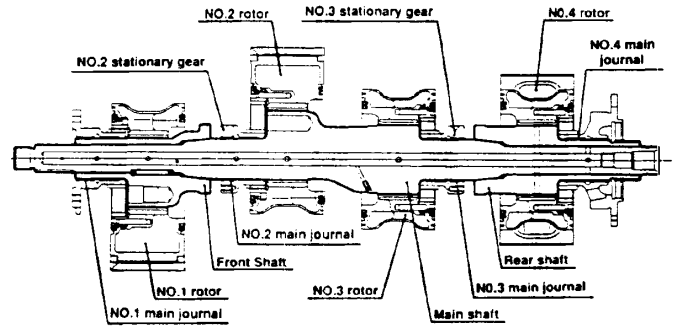

Fig. 7 Eccentric shaft

For rotational balancing, a counterweight is used at the front and rear of the eccentric shaft. Fig. 8 shows examples of rotor phase angles and the required counterweights. Taking the rotating counterweights and torque variations into consideration, ignition spacing of 90 degrees was provided for an ignition sequence of 1-3-2-4.

No	Layout	MR f (kg·mm)	MR r (kg·mm)	θ (deg)
A		28.8	28.8	135°
B		83.5	83.5	25°
C		0.0	0.0	180°

Fig. 8 Balancing of 4 rotors (Relation between rotor phase angle and counterweight)

To compensate for the reduced stiffness that the additional length of the 4-rotor engine might cause, and to increase the total stiffness of the engine, the tension bolts for the No. 1 and No.2 rotor housings and those for No. 3 and No. 4 were anchored in their respective center housings. This construction technique also helped facilitate the process of engine dismantling and reassembly for servicing. To further increase engine stiffness while still holding down added weight, an aluminum oil pan of honeycomb design was adopted and was installed atop the engine. Also, a stiffener of aluminum honeycomb cores sandwiched between carbon plates was incorporated.

Engine coolant enters the engine through the center housing and is diverted into the two rotor housings, one fore and one aft, before returning to the center housing. Lubricating oil also enters the center housing and flows into the front and rear pairs of rotor housings so that an equal amount of lubricant circulates through the housings, thus ensuring uniform temperature distribution.

(2) TELESCOPIC INTAKE MANIFOLD SYSTEM (TIMS)

It is a well known fact that the dynamic effect of intake airflow can be used to increase volumetric efficiency. The system adopted by Mazda employs telescopically-variable intake pipes, where the length of the pipes varies steplessly to match engine speed, thus providing a dynamic effect over a wider engine speed range.

The telescopic intake manifold system, schematically shown in Fig. 9, consists of cylindrical pipes inside which air funnels can slide. The length of the four intake pipes is controlled by varying the position of the air funnels. The sliding air funnels are as thin-walled as possible, and there are no protrusions in the air passages so as to minimize changes in airflow.

The sliding air funnels for No. 1 and No. 2 rotors are interconnected via a linear ball bearing, as are those for rotors No. 3 and No. 4. The linear ball bearing is arranged such that it slides along a guide projecting from the stationary pipe side, thus positioning the air funnels in their appropriate locations.

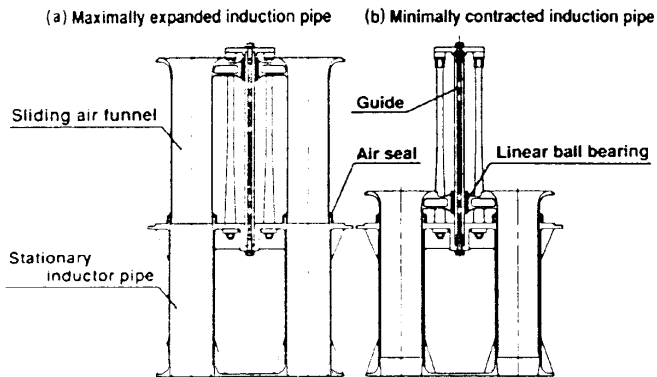

Fig. 9 Sectional view of telescopic intake manifold system

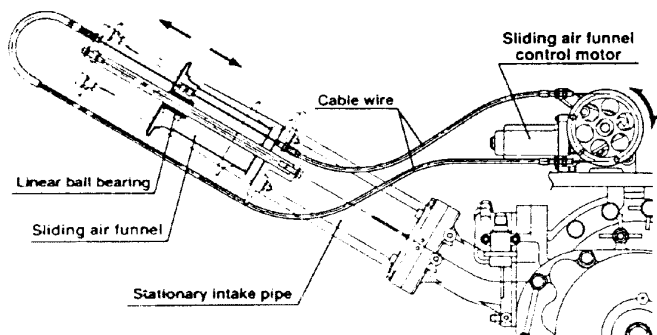

Fig. 10 Structure of telescopic intake manifold system

The air funnels operate via cable by a pair of DC motors as shown in Fig. 10. Each motor is provided with a potentiometer. The ECU reads a output of the potentiometers, detects the curter position of the air funnels, and

controls the DC motors to make the funnels move to the position which will provide the induction pipe the length predetermined for a given engine speed.

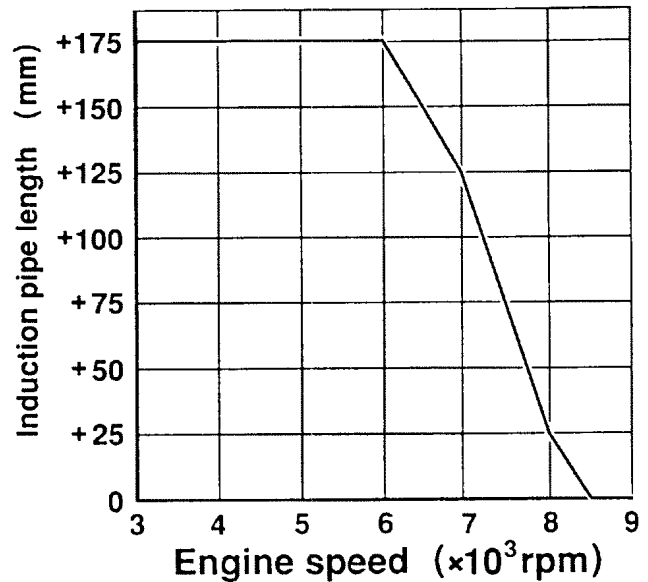

Fig. 11 Induction pipe length vs engine speed

Fig. 11 plots induction pipe length as a function of engine speed. Note that the length varies from its most extended position to the shortest over a range of 2500 rpm. The system completes the sliding operation in 0.5 s, which is sufficiently quick to follow, at minimum, full-power acceleration in second gear.

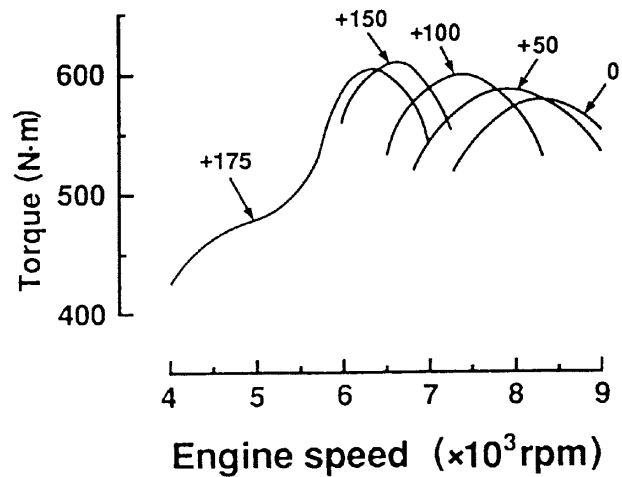

Fig. 12 Effect of variable induction pipe length

Fig. 12 shows the torque characteristics at different induction pipe lengths. The pipe is extended to bring in the torque peak at a lower engine speed, with maximum torque being higher than it would be at shorter pipe lengths. The TIMS pipe can slide a maximum of 175 mm. This difference in pipe length causes the engine speed at which the torque peak is delivered to shift by 2000 rpm between 6250 and 8250.

Fig. 13 shows time frequency in which the variable induction was used during the Le Mans race as a function of engine speed at full throttle. Assuming that this system's power band was 6000 rpm to 9000 rpm, virtually the entire range (approximately 95%) would then be covered by TIMS. Actually this system brought about a strong, flat torque curve across the entire operating range for the race.

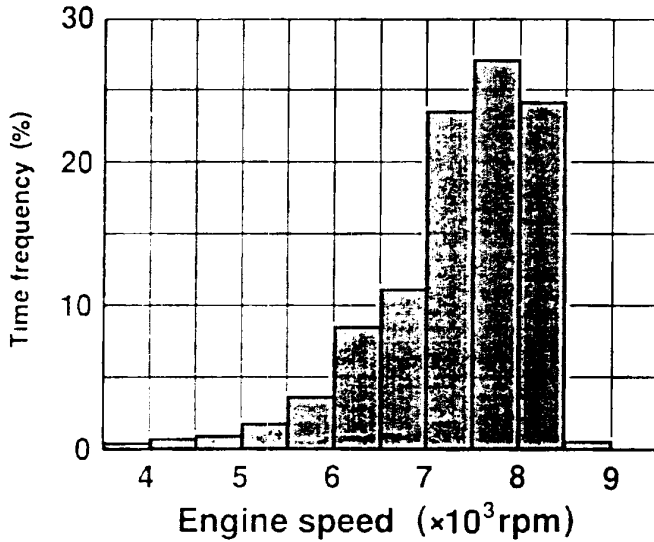

Fig. 13 Engine speed distribution in full throttle ('91 Le Mans)

(3) PERIPHERAL PORT INJECTION

On engines preceding the R26B, an air funnel injection (AFI) was used in which the injector was located upstream in the induction system to ensure good steady-state driving performance. Upstream injection caused a delay in fuel delivery to the combustion chamber, making it difficult for fuel delivery to keep up with the fast-charging airflow in transient periods. This would induce the air/fuel mixture to alternate between over-lean or over-rich, resulting in misfire and, therefore, temporary drops in torque. With previous engines, this problem in acceleration was solved by such methods as increasing fuel delivery by determining the level of acceleration based on change in throttle opening. Therefore, a slight mixture enrichment was allowed where acceleration was predictable. Such compensations proved considerably disadvantageous to driving fuel consumption.

For the R26B engine, the fuel injection system adopted was peripheral port injection (PPI), as illustrated in Fig. 14. The injector is now placed close to the intake port opening in the trochoid chamber. This layout minimizes the fuel delivery delay, thus improving throttle response.

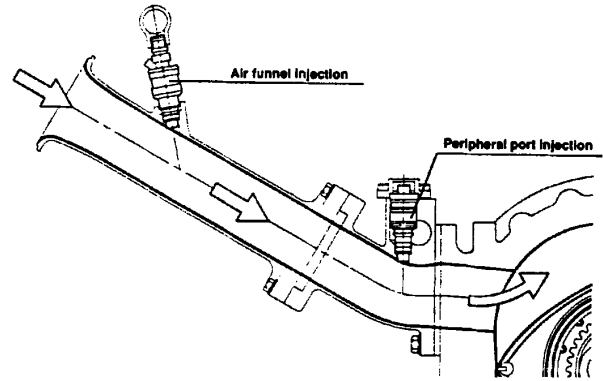

Fig. 14 Peripheral port injection & air funnel injection

Test condition: Wide-open acceleration is started from full-closed deceleration. (No fuel cut and no fuel delivery increase for acceleration)

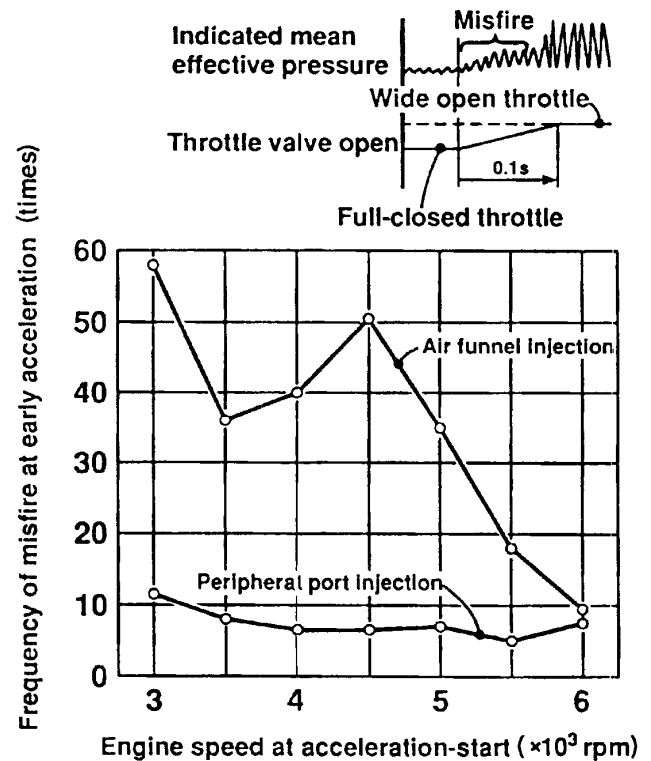

Fig. 15 Response at steep acceleration

Fig. 15 plots throttle response with AFI and PPI injector positions at different engine speeds, and gives a comparison of the frequency of misfires and partial misfires due to lean mixtures occurring when the fully-closed throttle would be opened abruptly to WOT. Switching to PPI was found to bring about a substantial improvement in throttle response.

Another benefit of PPI is considerable improvement in fuel consumption in actual driving. This is ascribable to enhanced air/fuel ratio controllability achieved and the resulting expanded fuel-cut zones.

(4) 3-PLUG IGNITION SYSTEM

The trailing side of the rotary engine's combustion chamber develops a squish which pushes back the flamefront as shown in Fig. 16.(2) With the conventional two-plug system, this squish prevents the flame from propagating to the combustion chamber's trailing end in the mid and high engine speed ranges. As a result, the mixture in the squish area is expelled in an unburned state.

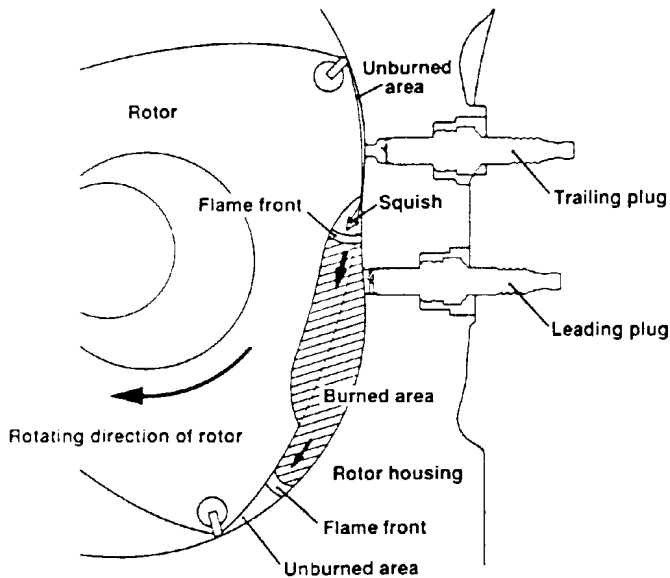

Fig. 16 Push back of flame front by squish

The 3-plug ignition system (Fig. 17) used in the R26B engine has an additional plug mounted toward the trailing side, positioned above the two original plugs. This extra plug ignites the mixture in the trailing side before the squish is generated, causing the mixture to burn completely and, also, speeding up flame propagation, which improves fuel consumption. The far trailing (FT) plug hole was made as small in volume as possible, within the range where combustion would not be affected, because when the apex seal is partially across the plug hole, and if the hole is large, there would be a direct path for the gas to flow from the high pressure area to the low pressure area.

The effectiveness of the 3-plug system is plotted in Fig. 18. Note that both engine output and fuel consumption benefit from the new system. Improvement in output, however, is not as great as in fuel consumption, probably due to some amount of gas blowing through the FT plug hole, thus causing some drop in volumetric efficiency.

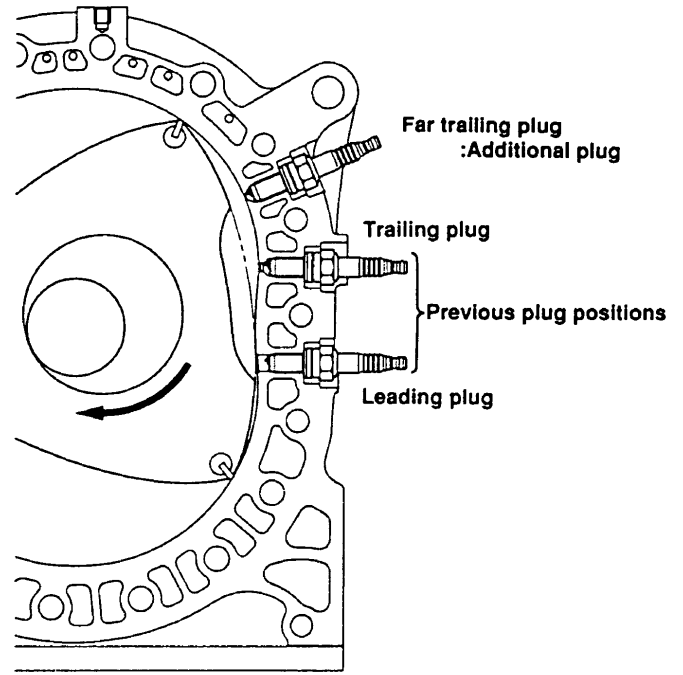

Fig. 17 3-plug ignition system

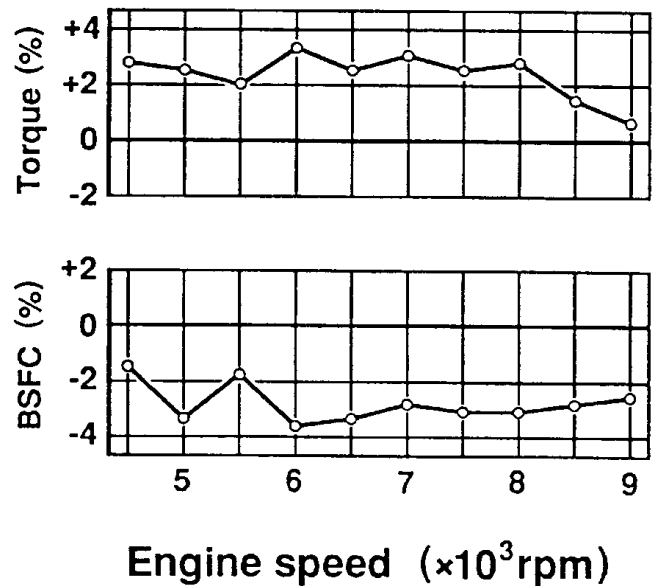

Fig. 18 Effect of 3-plug system on output and BSFC (Comparison with 2-plug system)

(5) 2-PIECE CERAMIC APEX SEAL

As engine power increased, the carbon apex seals used to date on previous racing engines had insufficient reserve strength. Therefore, a ceramic apex seal was developed in order to achieve, simultaneously, high levels of strength and wear resistance at high engine outputs.

In determining which ceramic materials to use, sliding properties, flexural strength, etc., were evaluated by rig tests, and finally a silicon-nitride base material was selected.(3) Fiber reinforcement was implemented to ensure toughness and strength. Short-fiber silicon-carbide whiskers were used to provide fracture toughness and wear resistance. Fiber concentration determination was based on combined wear resistance with good run-in performance characteristics. The properties of the carbon and fiber-reinforced ceramics are as shown in Table 2.

Table 2 Properties

Apex seal material	Carbon	Fiber reinforced ceramics
Hardness (Hv)	—	1700
Bending strength (MPa)	200 ~ 300	1200
Fracture toughness (MPa m ^{1/2})	3.5	6
Thermal shock resistance ΔT (°C)	400 ~ 600	>550
Density (g/cm ³)	2.1	3.3

The tough seal material developed paved the way to a 2-piece apex seal, which was superior in gas sealing performance. Fig. 19 shows the 2-piece seal configuration. Fig. 20 shows the performance improvement obtained by the 2-piece seal, and it is to be noted that torque increased throughout the entire driving engine speed range.

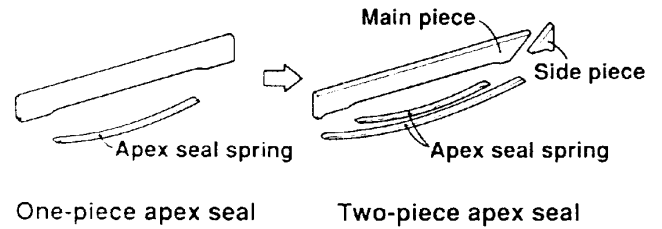

Fig. 19 Modification of apex seal

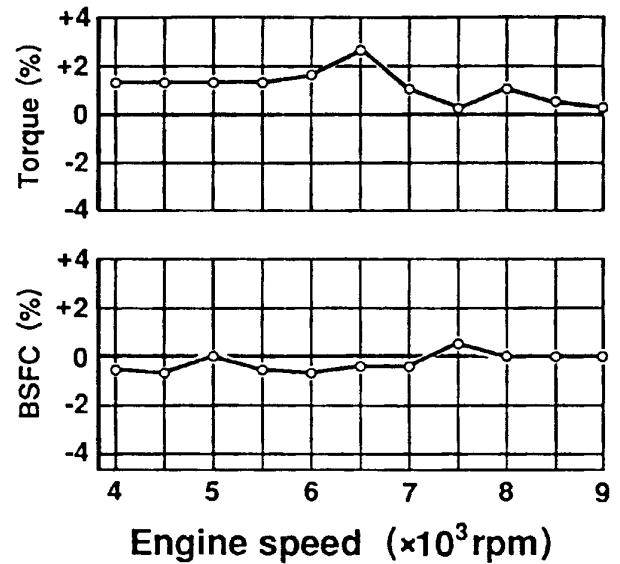

Fig. 20 Effect of 2-piece apex seal on output and BSFC (Comparison with one-piece apex seal)

(6) CERMET COATING ON INTERIOR SURFACES OF HOUSING

Previously, the internal surfaces of the rotor housings and side housings suffered considerable wear due to the apex seals, side seals, and oil seals sliding at high speed and high load. To increase wear resistance and to reduce friction, all the surfaces rubbed by the gas seals (Fig. 21) were coated with chrome-carbide base cermet, using detonation gun spray.

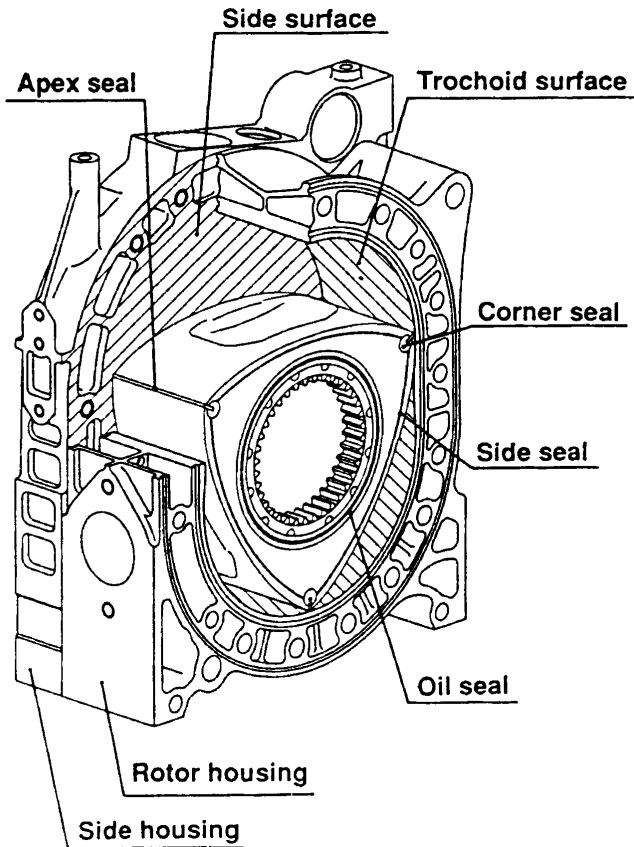

Fig. 21 Cermet coating (Shaded area)

Carbide-base cermet coating is known to provide superior wear resistance in high-temperature environments. A chrome-carbide base coating was selected to ensure ease of machining. Reciprocating sliding-wear rig testing (Fig. 22) produced results that allowed a comparison of the detonation gun sprayed coating with a gas soft-nitrided cast iron (Fig. 23). Note that the detonation gun sprayed coating shows less wear. Similar results were noted in on-engine testing as well.

Providing stable cermet coating is important to secure engine reliability, and of utmost importance in preventing exfoliation of the coating during driving. Regarding exfoliation, various processes were investigated to solve variation factors, and based on the results obtained, a process was developed which gave products both high reliability and stability.

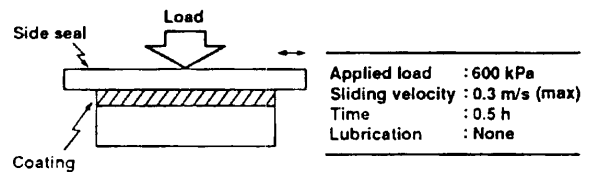

Fig. 22 Test condition of reciprocating wear rig

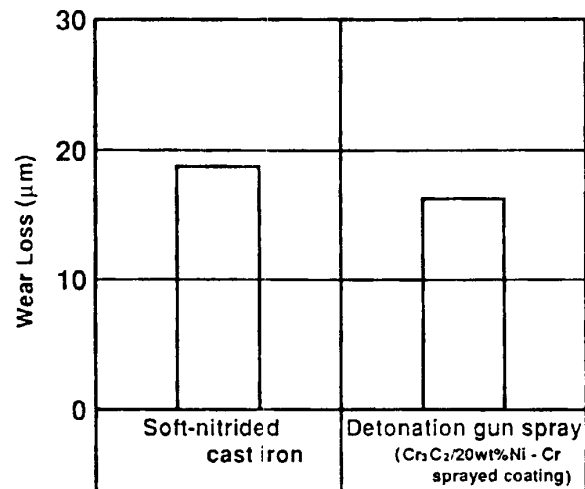

Fig. 23 Result of reciprocating wear rig tests

ENGINE PERFORMANCE AND CONDITION OF MAIN PARTS AFTER 1991 LE MANS ENDURANCE RACE

For a racing car to run the total race distance at high speeds, especially in an endurance event, it is essential that the deterioration of its engine and principal parts be kept to a minimum. Fig. 24 shows the R26B's engine performance and fuel consumption after the 1991 Le Mans. It should be noted that the engine exhibited stable performance with virtually no performance deterioration.

Also, during engine dismantling, wear of the apex seals, rubbed surfaces of the housings, bearings, etc. were found to be 1/2 or 1/3 the upper limits of tolerance, indicating remarkable durability and reliability.

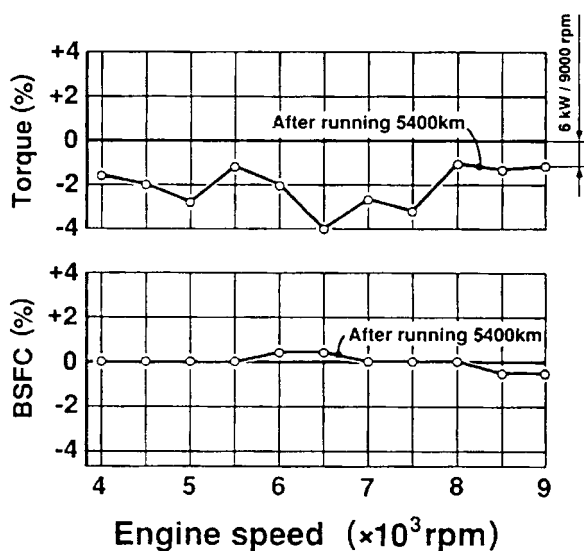

Fig. 24 Output and BSFC after finishing the 1991 Le Mans race

SUMMARY

The R26B rotary engine and the technologies employed to improve its output, fuel consumption, and reliability have been expounded in this paper. These technologies have brought about the following specific results:

- (1) The telescopic intake manifold system has had the effect of increasing engine torque across the driving range.
- (2) The peripheral port injection (PPI) has helped to enhance throttle response, while improving fuel consumption. These improvements have been the result of the more accurate control of air/fuel ratio during transient operating conditions.
- (3) The three-plug ignition system was useful to improve fuel consumption and torque.

- (4) The ceramic apex seal increased fracture resistance and wear resistance, making it possible to employ the better sealing, 2-piece apex seal for stronger engine torque.
- (5) The cermet coating on the interior walls of the housings provided higher wear resistance with consequent increases in durability and reliability.

ACKNOWLEDGEMENT

The technologies employed to improve the 4-rotor R26B engine's output, fuel consumption, and durability/reliability led to Mazda's overall victory in the 1991 Le Mans endurance race. It was the valuable contributions and support from the various departments at Mazda and many outside organizations that made the technological developments possible. We thank them all, and, with their continued assistance and guidance, we will continue our efforts to further upgrade and improve our racing engines.

REFERENCES

1. Tadokoro, T., et al. "Three-rotor Rotary Engines for Motor Sports", Mazda Technical Review, No.6, 1988
2. Nagao, A., et al. "Analysis of Flame Propagation and Knocking in a Rotary Engine", Mazda Technical Review, No.4, 1986
3. Takami, A., et al. "Fiber Reinforced Ceramics", Mazda Technical Review, No.8, 1990