Developed Technologies of the New Rotary Engine (RENESIS)

**Masaki Ohkubo, Seiji Tashima, Ritsuharu Shimizu,
Suguru Fuse and Hiroshi Ebino**
Mazda Motor Corporation

Reprinted From: **Advanced Powertrains on CD-ROM from the SAE 2004 World Congress
(SP-1836)**

ISBN 0 7680 1423-9



9 780768 014235

SAE *International*[™]

**2004 SAE World Congress
Detroit, Michigan
March 8-11, 2004**

All rights reserved. No part of this publication may be reproduced, stored in a retrieval system, or transmitted, in any form or by any means, electronic, mechanical, photocopying, recording, or otherwise, without the prior written permission of SAE.

For permission and licensing requests contact:

SAE Permissions
400 Commonwealth Drive
Warrendale, PA 15096-0001-USA
Email: permissions@sae.org
Fax: 724-772-4891
Tel: 724-772-4028



For multiple print copies contact:

SAE Customer Service
Tel: 877-606-7323 (inside USA and Canada)
Tel: 724-776-4970 (outside USA)
Fax: 724-776-1615
Email: CustomerService@sae.org

ISBN 0-7680-1319-4
Copyright © 2004 SAE International

Positions and opinions advanced in this paper are those of the author(s) and not necessarily those of SAE. The author is solely responsible for the content of the paper. A process is available by which discussions will be printed with the paper if it is published in SAE Transactions.

Persons wishing to submit papers to be considered for presentation or publication by SAE should send the manuscript or a 300 word abstract of a proposed manuscript to: Secretary, Engineering Meetings Board, SAE.

Printed in USA

Developed Technologies of the New Rotary Engine (RENESIS)

Masaki Ohkubo, Seiji Tashima, Ritsuharu Shimizu, Suguru Fuse and Hiroshi Ebino
Mazda Motor Corporation

Copyright © 2004 SAE International

ABSTRACT

The newly developed rotary engine has achieved major progress in high performance, improved fuel economy and clean exhaust gas by innovative action. The engine of the next generation is named RENESIS, which stands for "The RE (Rotary Engine)'s GENESIS" or the rotary engine for the new millennium.

The peripheral exhaust port of the previous rotary engine is replaced by a side exhaust port system in the RENESIS. This allows for an increase in the intake port area, thus producing higher power. Exhaust opening timing is retarded to improve thermal efficiency. The side exhaust port also allows reducing the internal EGR, stabilizing the combustion at idling. The improved thermal efficiency and the stabilized idle combustion result in higher fuel economy.

In addition, the side exhaust port allows a reduction of the HC mass, realizing reduced exhaust gas emission. A Sequential Dynamic Air Intake System is adopted which optimizes air intake depending on the actual engine speed range, producing high torque ranging from low to high engine speeds. Gas seals were optimized for the side exhaust port RE.

INTRODUCTION

In order for the rotary engine (RE) to keep meeting a wide range of market needs as an automotive engine, its performance needs to be improved while making a drastic improvement to the fuel economy and the exhaust gas emission at the same time. Therefore Mazda has researched the side exhaust port system as the improvement to RE's essential area, and have reported its improvement potential for the fuel economy and the exhaust gas emission. [1]

Compared to the peripheral exhaust port of previous RE, the side exhaust port offers more design freedom for the intake/exhaust port shape. This allows for port timing and shape setting, which enables balanced output, fuel economy and exhaust gas emission. This paper describes an overview of the RENESIS and technologies.

TARGET OF RENESIS DEVELOPMENT

The RENESIS was developed targeting at high output power with natural aspiration, but at the same time stringent emission regulations in relevant markets and a high fuel economy were to be met to target high performance RE accepted in the 21st century. The engine development aimed at:

- (1) Realizing smooth and high power from low to high engine speed.
- (2) Drastic improvement in fuel economy.
- (3) Reduction of exhaust emissions.

RENESIS MAJOR SPECIFICATIONS

The RENESIS is more simple and compact outside view than the previous model turbo-charged as shown in Fig. 1.

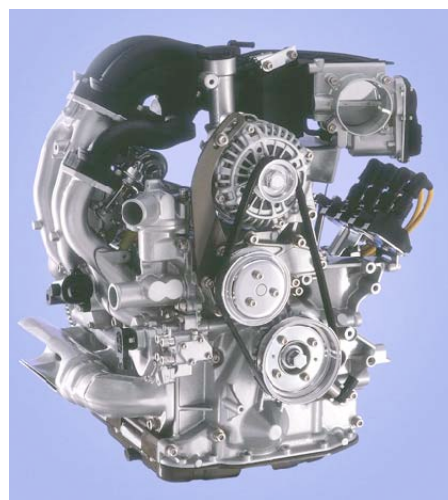

Fig.1: Photo of RENESIS Engine

AS shown in Table 1, RENESIS has two versions of High power and Standard power, and they have the different output characteristics and allowable engine speed. The RENESIS has the exhaust ports in the side housings and higher compression ratio than the previous model (13B-REW).

Table 1: Major Specifications

Engine		RENESIS		13B-REW (RX-7)	
		High-Power	Standard-Power	654 × 2	
Displacement (cc)		654 × 2	654 × 2	654 × 2	
Eccentricity × Generating Radius × Width (mm)		15 × 105 × 80	15 × 105 × 80	15 × 105 × 80	
Intake Type		Side Intake	Side Intake	Side Intake	
Exhaust Type		Side Exhaust	Side Exhaust	Peripheral Exhaust	
Compression ratio		10.0	10.0	9.0	
Port Timing	Primary	I.O.(ATDC)	3°	3°	45°
		I.C.(ABDC)	65°	60°	50°
	Secondary	I.O.(ATDC)	12°	12°	32°
		I.C.(ABDC)	36°	45°	50°
	Auxiliary	I.O.(ATDC)	38°	n/a	n/a
		I.C.(ABDC)	80°	n/a	n/a
Exhaust	E.O.(BBDC)	50°	40°	75°	
	E.C.(BTDC)	3°	3°	48° ATDC	
Intake System		S-DAIS	S-DAIS	Non Variable	
Intake Charge Type		Natural Aspiration	Natural Aspiration	Sequential Twin-Turbo	

Fig. 2 shows the schematic of the fuel and the emission control system. The high-power RENESIS is fitted with a 32-bit PCM operation for optimum fuel injection supported by three injectors per rotor to improve fuel economy, response and power simultaneously.

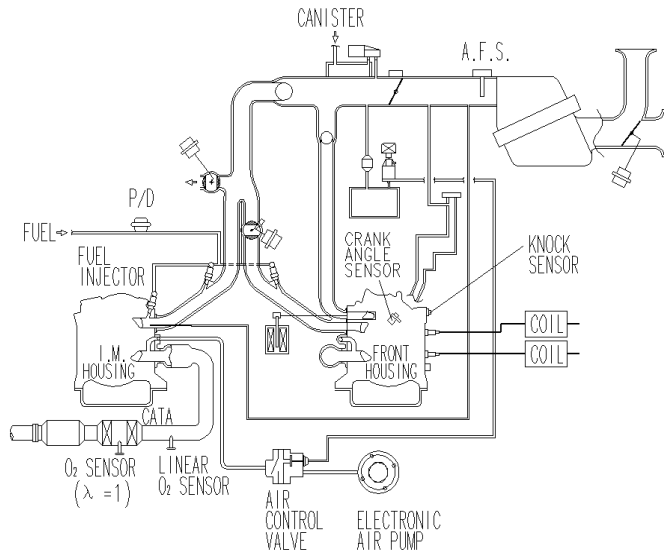

Fig.2: Fuel & Emission Control System (High-Power)

For the aim of the RENESIS development, additional technologies are adopted based on the side exhaust as shown in Table 2.

Table 2: Major Technologies

Aim of development	Adopted Technologies	
Higher and Smoother Output Power	Side Exhaust Port	Enlarged Intake Port Area
		Enlarged Exhaust Port Area
	S-DAIS (Sequential Dynamic Air Intake System)	
Improved Fuel Economy	Side Exhaust Port	No Intake/Exhaust Overlap
		Retarded Exhaust Open Timing
	Cut-Off Seal	
	Jet Air/Fuel Mixing System	
Improved Exhaust Emission	Side Exhaust Port	Improved HC Emissions
	Exhaust Port Insert	
	Dual Wall Exhaust Manifold	

BASIC PERFORMANCE

1. Engine Output Performance

The high-power RENESIS output performance is 177kW at 8500rpm, 216N·m at 5500rpm. The standard-power RENESIS is 147kW at 7200rpm, 222N·m at 5000rpm. Torque curves are shown in Fig.3.

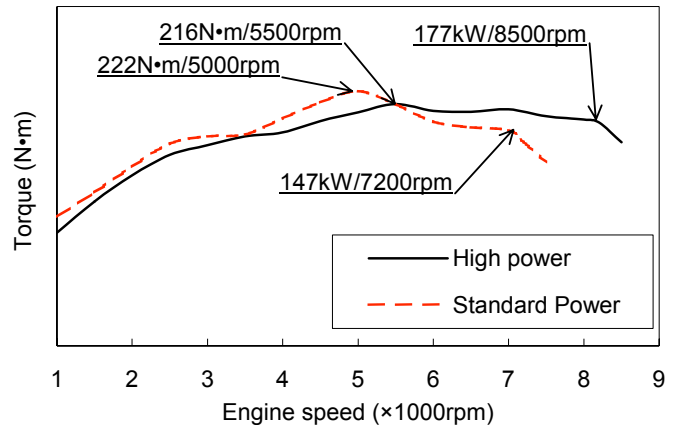

Fig.3: Engine Output Performance

2. Fuel Economy

Brake specific fuel consumption of the RENESIS is improved from previous model by 8 – 15% as shown in Fig.4.

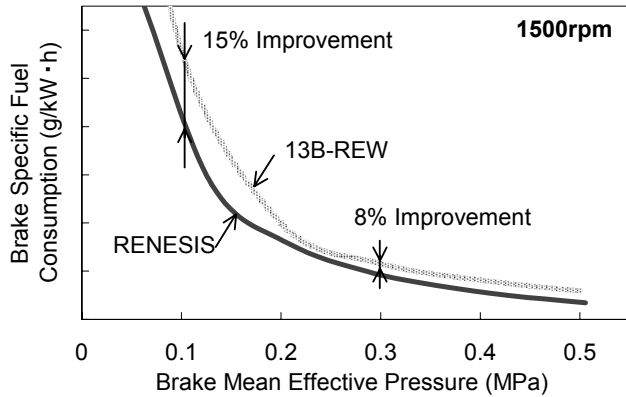

Fig.4: Fuel Consumption

3. Emission Regulation Conformity

As hydrocarbon (HC) emission characteristics of the RENESIS as shown in Fig.5, the use of the side exhaust port allowed for about 35 – 50% HC reduction compared to the 13B-REW with the peripheral exhaust port. With this reduction, the RENESIS vehicle meets USA LEV-II (LEV).

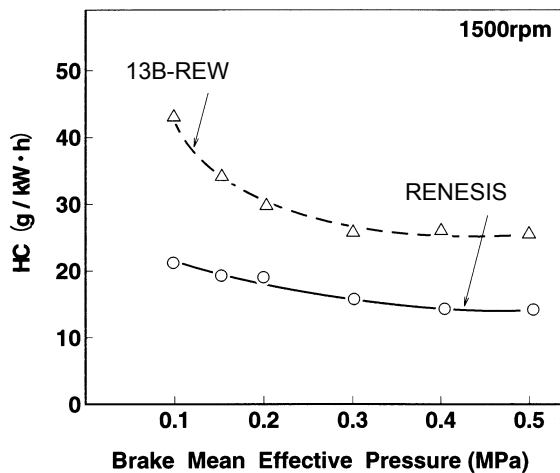

Fig.5: HC Emission

MAJOR TECHNOLOGIES

1. Adoption of the side exhaust port

The most important technology of the RENESIS is the side exhaust port. The peripheral exhaust port of the previous RE, mounted at the rotor housings, were moved to the side housings for the RENESIS. (See Fig. 6) The major advantage of the side exhaust port is that it offers more design freedom for the intake/exhaust port shape. With the peripheral exhaust port of the previous RE, an intake/exhaust overlapping period is relatively large due to the layout of them. Therefore, this design caused unstable combustion in the low engine speed with light load range, so that air/fuel ratio was enriched beyond stoichiometric ratio in that region. Previous RE with the peripheral exhaust port also had early exhaust opening timing. This prevented long expansion stroke, which was unfavorable in terms of thermal efficiency. Therefore, the side exhaust port was adopted as a necessary step. The adopted major technologies described below are based on the side exhaust port.

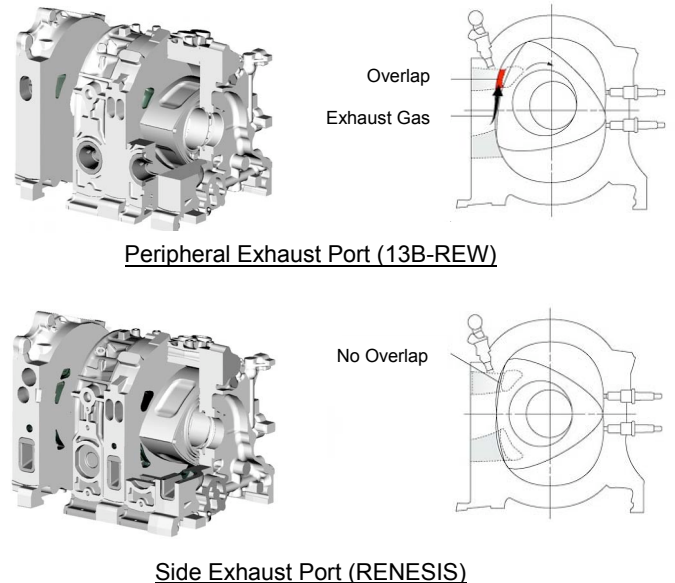

Fig.6: Peripheral Exhaust Port versus Side Exhaust Port

2. Output Improvement Technologies

2.1. Increase of the intake/exhaust port areas

The greatest advantage of the side exhaust port is that it enables exhaust closing time to be set around exhaust

TDC (EC=3 degree BTDC) while securing enough exhaust port area. This allowed intake opening to be set at early timing (IO=3 degree ATDC) without any overlap with the exhaust and the intake port areas as shown in Fig. 7.

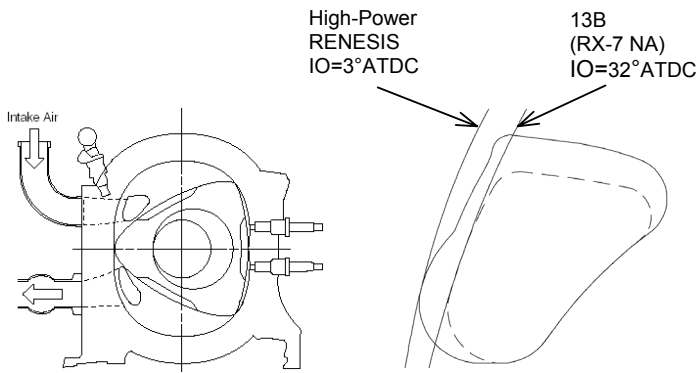

Fig.7: Increase of Intake Port Area

In consequence, the high-power RENESIS achieves 40% higher output compared to the previous natural aspiration peripheral exhaust port RE(13B). (See Fig.8)

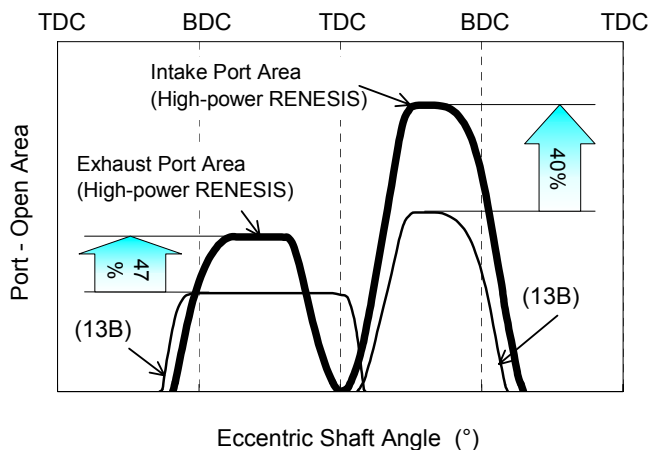

Fig.8: Port Open Area Characteristics

In order to maximize the intake/exhaust port areas, the rotor side seal's groove position is offset outward by 2mm. The exhaust ports are located at both sides and the two exhaust ports between the front and the rear rotors are connected but the exhaust port insert is used to separate the path. (See Fig.9)

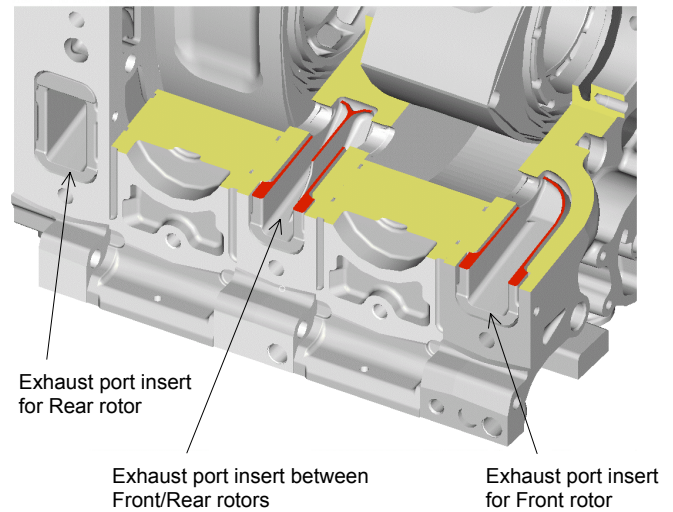

Fig.9: Exhaust Port Insert

2.2. Sequential Dynamic Air Intake System (S-DAIS)

The high-power RENESIS has three intake ports per rotor: primary, secondary and auxiliary intake port (six intake ports in total on the two rotors). Their opening and closing timings are different. (See Fig.10)

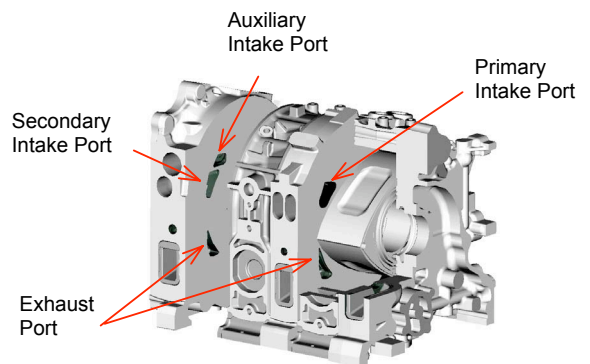

Fig.10: Multi Side Port

And four valves are adopted in intake streaming. The S-DAIS control the intake manifold length and intake closing timing according to the engine speed, getting maximum dynamic boost effects. (See Fig.11,12,13) This enables the RENESIS to deliver smooth high torque from low to high engine speed.

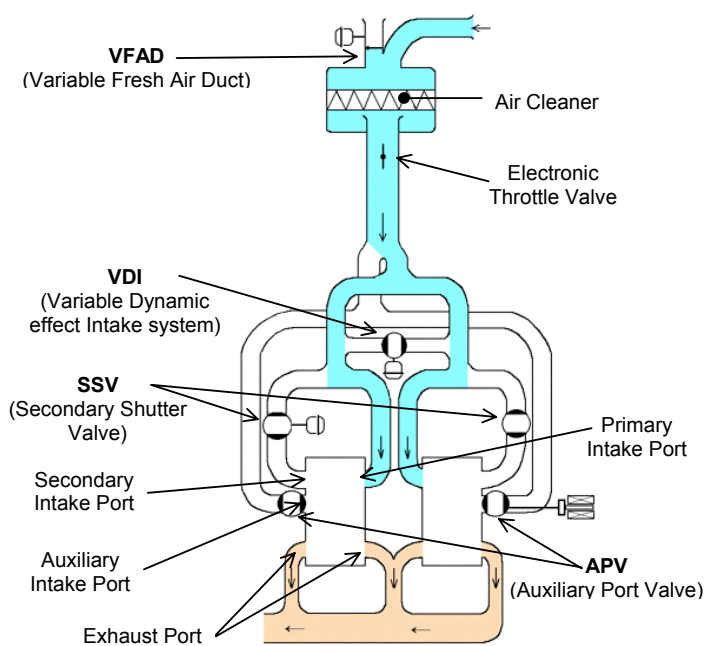

Fig.11: S-DAIS (High-Power ~3750rpm)

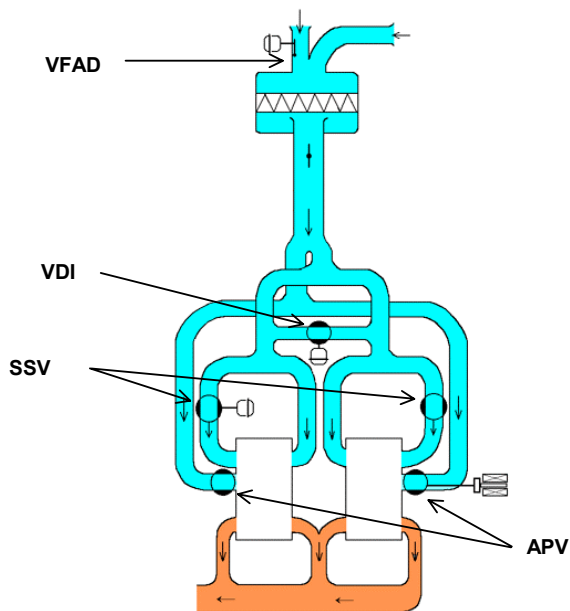

Fig.12: S-DAIS (High-Power 7250rpm~)

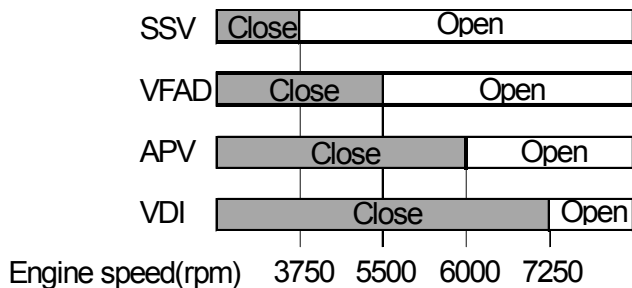

Fig.13: S-DAIS Valve Control

The high-power RENESIS with S-DAIS has high charging efficiency at wide range of engine speed as shown in Fig.14.

Standard-power RENESIS, which has high torque in the most commonly used engine speed range, uses four ports in total on the two rotors (auxiliary port is not included), and controls the two valves.

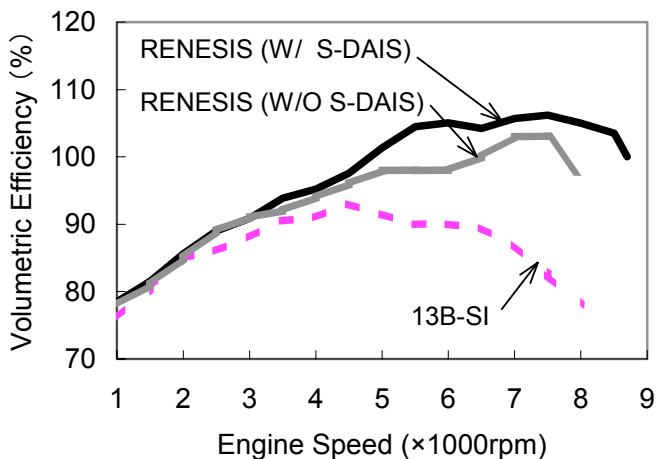

Fig.14: Effects of S-DAIS

3. Fuel Economy

3.1.Overlap Eliminated and cut off seal

With the side exhaust port, the intake port and the exhaust port are laid out on the same surface of the side housing, causing intake/exhaust ports to communicate on the rotor side face and the exhaust gas flows into the intake port. Because of this, cut-off seals were added to the rotor side face to shut off the communication path of the intake/exhaust ports. Further a side clearance between a rotor and the side housing was reduced by 18% and the rotor side face was machined to make a

step in order to limit the burned gas flow to minimum. (See Fig. 15)

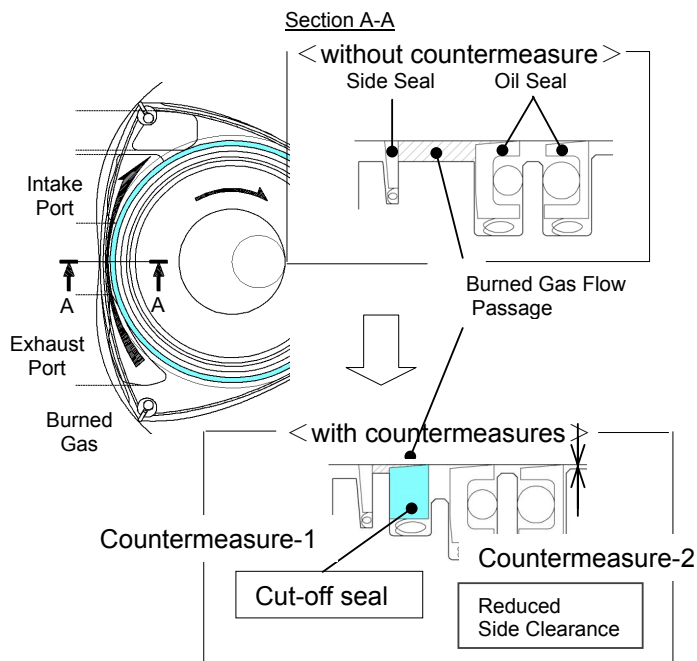
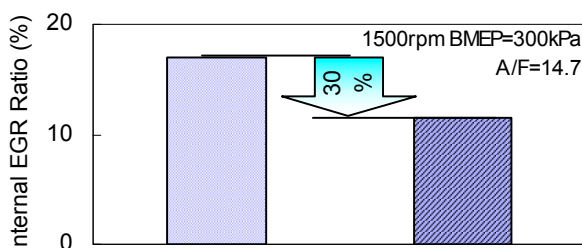

Fig.15: Burned Gas Flow Passage on Rotor Side

The use of the side exhaust port and cut-off seal eliminated overlap of intake and exhaust port. In addition, setting the exhaust closing timing at extremely close to the top dead center and increasing compression ratio from 9.0 to 10.0 could minimize containment volume of the exhaust gas at exhaust close timing, reducing the internal EGR. (See Fig. 16) These have improved combustion stability in the low-speed and light load range. Secondary air supply to the exhaust ports during actual drive was eliminated. As a result, fuel increase could also be eliminated, leading to the drastic improvement to the fuel economy.



	Peripheral Exhaust Port (13B-REW)	Side Exhaust Port (RENESIS)
Intake/Exhaust Overlap	16 deg	0 deg
Exhaust Close Timing	48° ATDC	3°BTDC
Compression Ratio	9.0	10.0

Fig.16: Decrease of Internal EGR Ratio

3.2. Increase of Expansion Ratio

The exhaust opening timing could be retarded still securing enough area of the exhaust port and improving the expansion ratio: all resulting in better thermal efficiency. Fig. 17 shows impact of exhaust opening timing on the fuel economy.

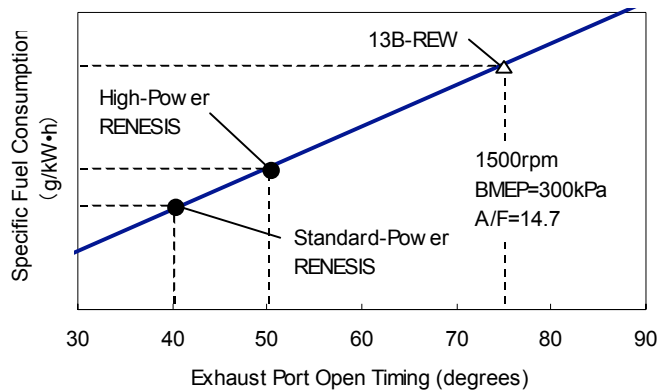

Fig.17: Effects of Exhaust Port Open Timing

3.3. Jet Air/Fuel Mixing System

Improvement of the fuel flow rate and the exhaust gas emission at idling requires stable transportation of small amounts of injected fuel to spark plugs. We designed a jet air/fuel mixing system in a way that jet air was sprayed from a pipe (port air bleed) to the bottom face of the primary intake port (anti-wet port), which created an upward and accelerated air flow. The high velocity air stream prevents fuel from wetting the intake port wall and facilitates vaporization and mixing of the air and fuel. (See Fig.18)

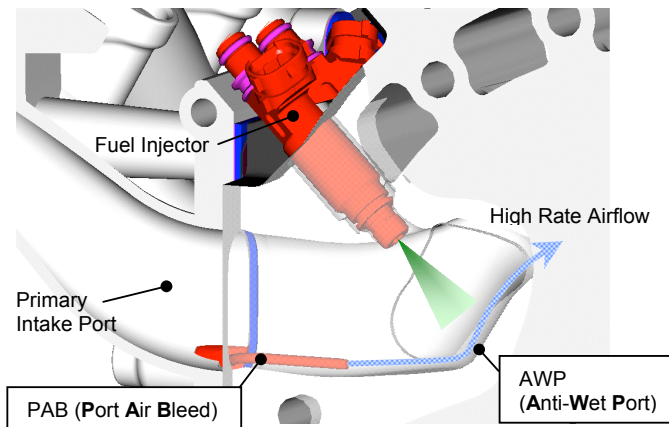

Fig.18: Jet Air/Fuel Mixing System Structure

The jet air/fuel mixing system has improved combustion stability and also reduced HC emission and fuel flow rate at idling. (See Fig. 19 and 20)

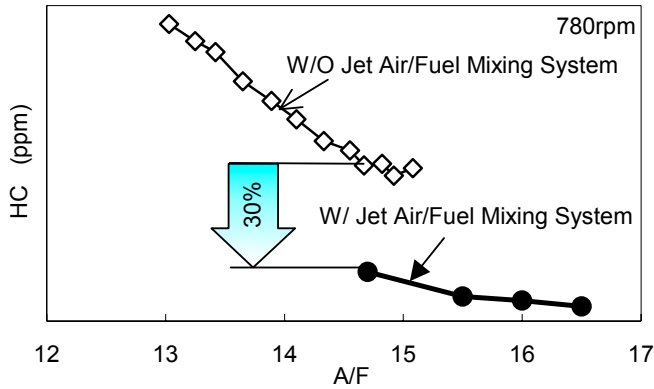

Fig.19: Effects of Jet Air/Fuel Mixing System on HC Emissions at Idling

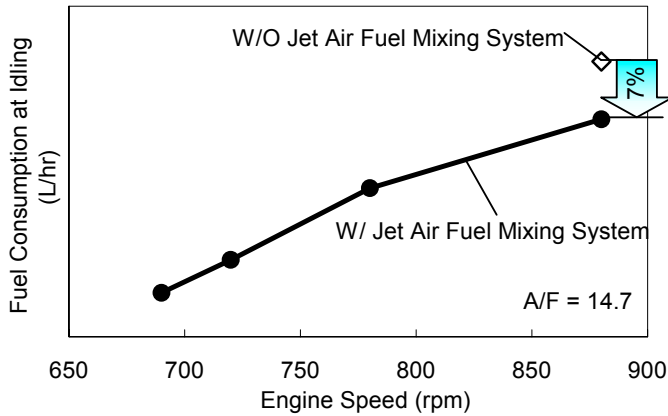

Fig.20: Effects of Jet Air/Fuel Mixing System on Fuel Consumption at Idling

4. Emission Improvement Technologies

4.1. Reduced HC Emission at Trailing Side of Combustion Chamber

Air/fuel mixture tends to be difficult to burn in the combustion chamber of the peripheral exhaust port RE at the end of the trailing side, which causes the apex seal to scrape HC on the trochoid wall face, causing high HC concentration at the end of the trailing side. As Fig. 21 shows, as the end of the trailing side of the combustion chamber nears the exhaust ports, concentration of the HC emission increases. As shown in Fig. 22, the end of the trailing side does not directly close to the side exhaust ports. From this reason, HC at this area is difficult to be emitted into the side exhaust port and it is transported to the next process, causing re-burn.

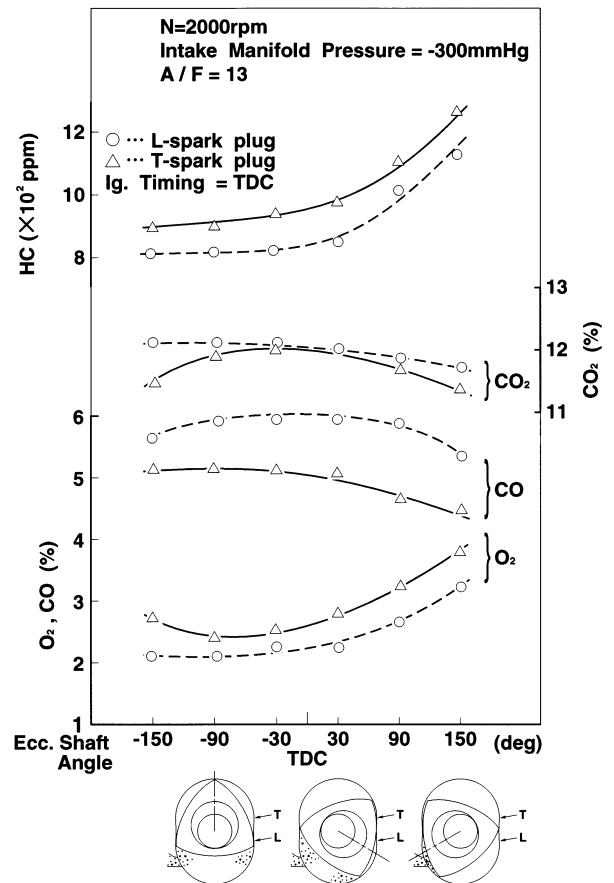

Fig.21: Mechanism of HC Emission

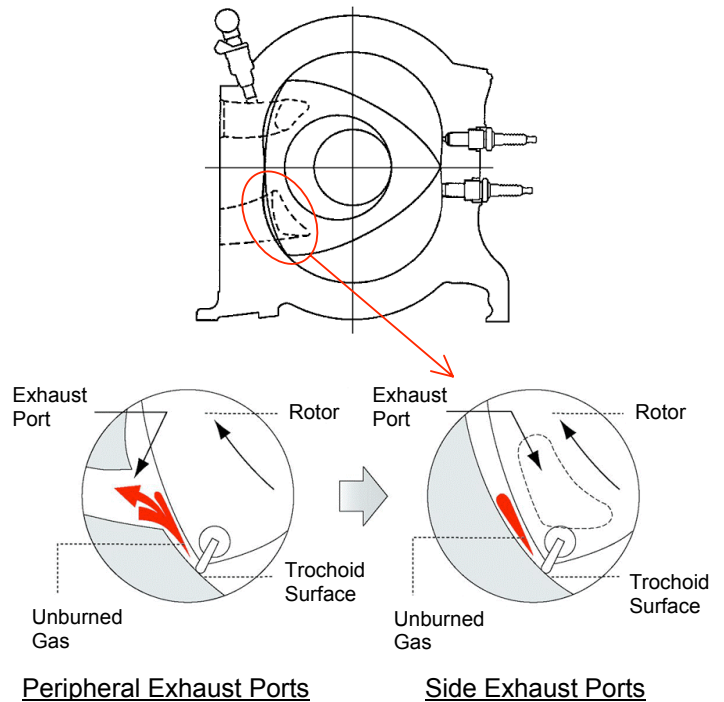

Fig.22: Mechanism of HC Emission Around T-side End

Fig. 23 shows HC characteristics of the side exhaust port RE and peripheral exhaust port RE. HC of the side exhaust port RE has been reduced by about 35 – 50% from the peripheral exhaust port RE. HC reduction is specifically great at light load range for the side exhaust port RE because effects of the improved combustion stability is incorporated in addition to the above effects.

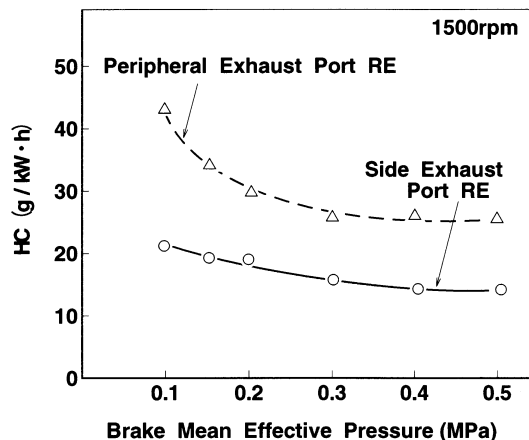

Fig.23: HC Emission

4.2. Retaining Heat of the Exhaust Gas

In order to retain heat of the exhaust gas from the combustion chamber to the catalyst, two measures were taken: The exhaust port has a stainless thin-walled insert (made of heat resisting stainless alloy) and the exhaust manifold has two layers of air layer for heat insulation and small volume thin-wall inner tube. This allows for the retention of exhaust gas heat from combustion chamber to the catalyst. Because of the heat retention, gas temperature at a catalyst upstream could increase about 140 degree C in the USA LA-4 mode drive, improving catalyst's conversion capability. Fig. 24 shows structure of the exhaust port insert and exhaust manifold.

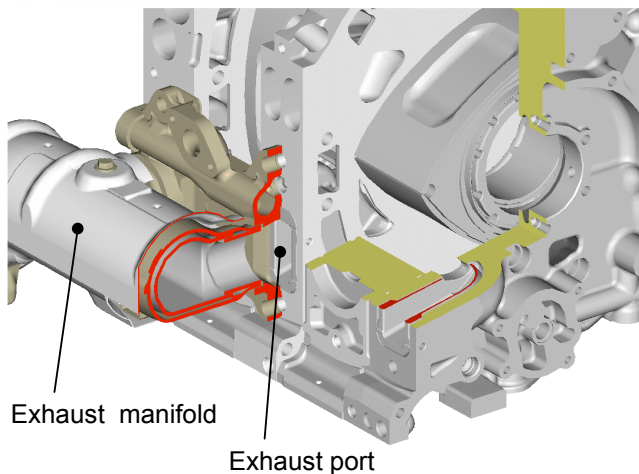

Fig.24: Exhaust Port Insert & Exhaust Manifold

Fig. 25 presents the comparison data of the RENESIS's exhaust gas temperature at catalyst upstream. Combining with introduction of the secondary air into the exhaust gas by electric air pump for cold engine allows for the quick rise of the exhaust gas temperature, assisting catalyst quick light-off.

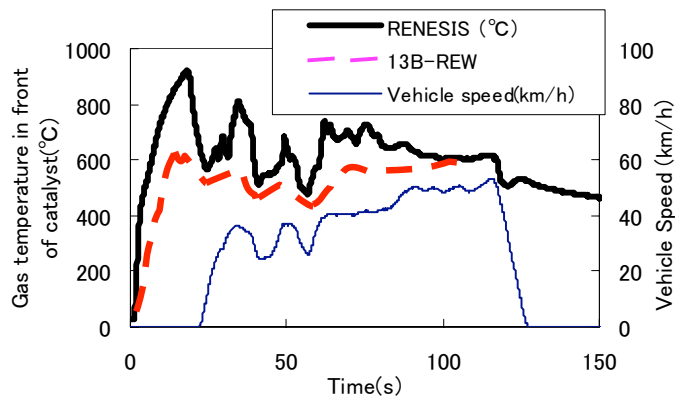

Fig.25: Gas Temperature at Catalyst upstream

5. Technological Adaptations for Reliability Improvement

Apex seals, corner seals and side seals were refined to maintain each life equal to the previous model (13B-REW).

5.1. Keystone-Type Side Seal

Side seals pass over the side exhaust ports. Because of this, burned gas flows into a side seal groove, which then caused carbon deposit in the groove, resulting in the side seals stuck in the groove. (See Fig.26) Therefore, we designed the side seals section into a keystone shape to intentionally change side seal clearance between the side seal and the rotor's groove. This made it difficult for carbon to deposit, eliminating the stuck. There is not stick with the keystone-type side seal as shown in Fig.27.

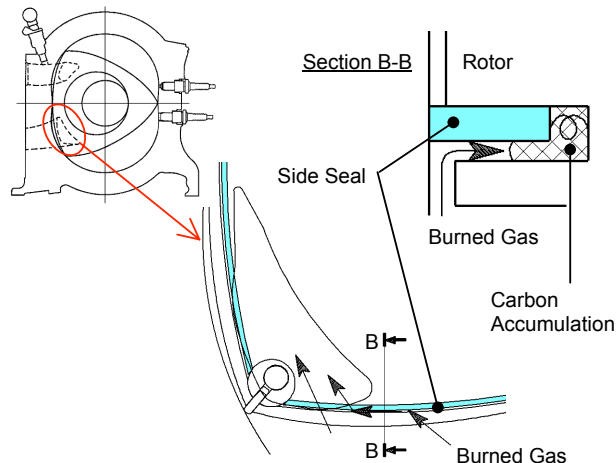

Fig.26: Side Seal Carbon Stuck Mechanism

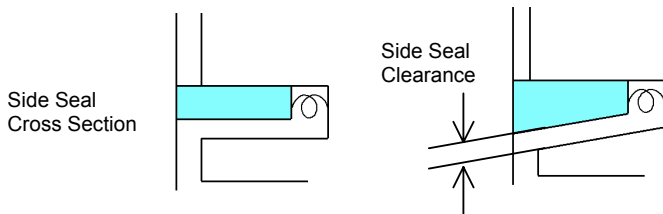
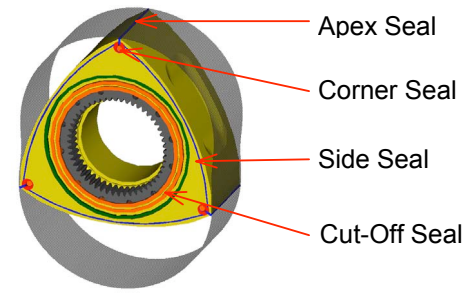
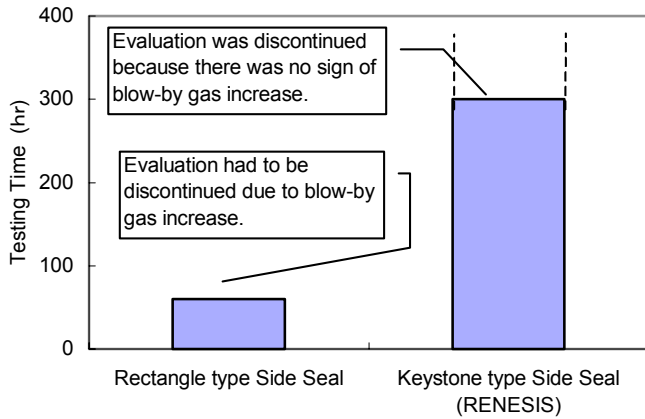

Fig.27: Effects of Keystone Side Seal on Side Seal Carbon Stuck

5.2. Low-height Apex Seal

With the peripheral exhaust port, there was little oil film on an apex seal when the seal passed the peripheral exhaust port. This issue was resolved in the side exhaust ports, reducing the apex seal size. (See Fig.28) As a result, centrifugal force working on the apex seal at high engine speed reduces, decreasing the frictional resistance and wear of the apex seal. Moreover, because the apex seal could be made more flexible, improving the seal's fit to the trochoid surface enhanced its sealing ability.

The apex seal is pressed against the trochoid face mainly by the gas pressure flowing into the apex seal's groove bottom of the rotor. Because the RENESIS has a small apex seal and higher engine speed limit than previous RE, we re-studied clearance, etc. Fig.29 shows numerical analysis results of the apex seal's kinetic characteristics at the engine speed limit. By this analysis result and vehicle evaluation, optimum clearance and shape were established within the operation conditions.

Parts name	RENESIS Side Exhaust Port RE	13B-REW (RX-7) Peripheral Exhaust Port RE
Cut-Off Seal	Tapered Expansion Spring Ring Material: Spheroidal Graphite Cast Iron	n/a
Side Seal	t=1.2 Keystone Material: Sintered Alloy (iron based)	t=0.7 Rectangle
Apex Seal	Apex Seal of 2 Pieces Low Profile Material: Chilled Cast Iron	Apex Seal of 3 Pieces
Corner Seal	Flexibly Bending Type with Metal Plug Material: Cast Iron ; Cr-plating + DLC-coating	Flexibly Bending Type with Rubber Plug Material: Cast Iron ; Cr-plating

Fig.28: Gas Seals Major Specifications

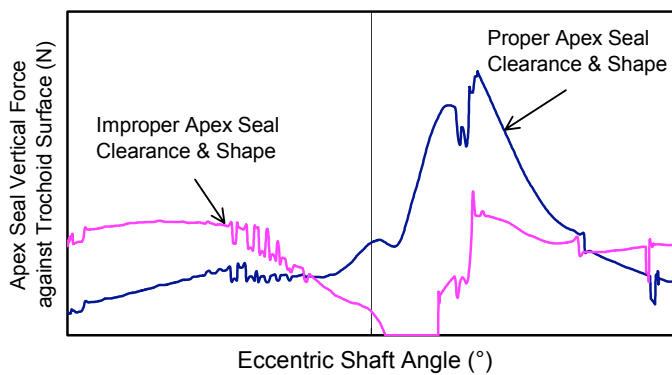
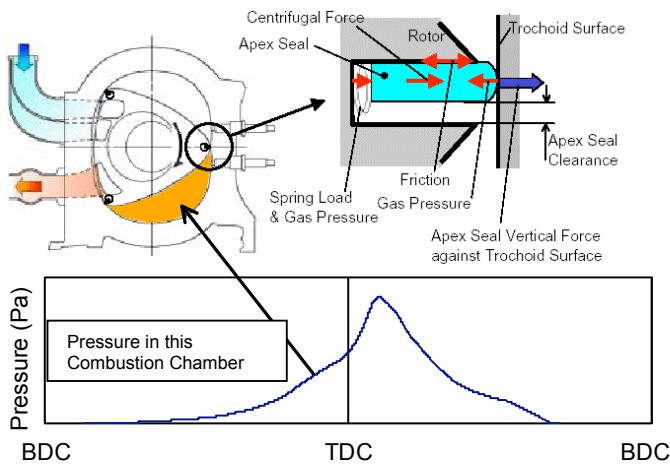

Fig.29: Kinetic Analysis of Apex Seal at 9000rpm (numerical study)

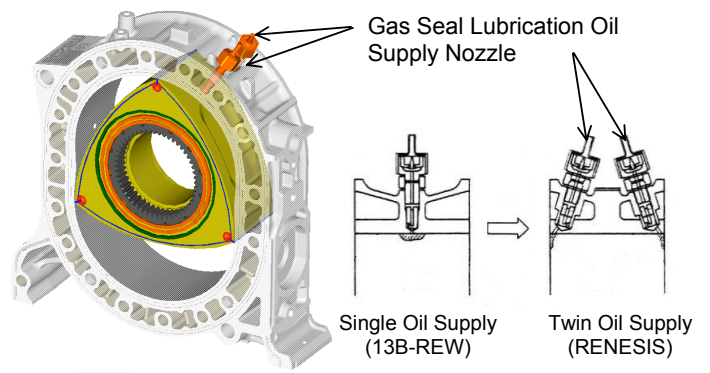

Fig.30: Twin Direct Oil Supply

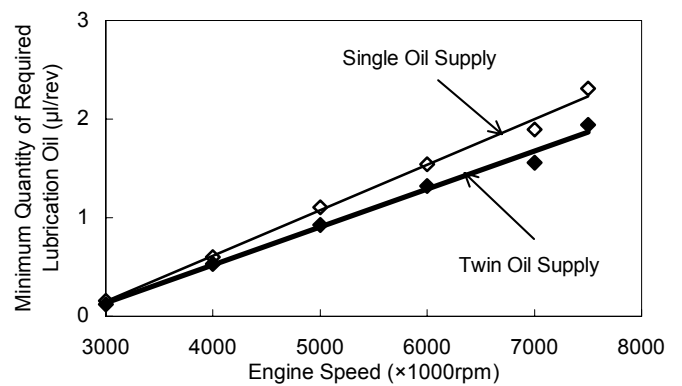

Fig.31: Effects of Twin Direct Oil Supply

5.3. Optimizing Lubrication using Twin Direct Supply

The temperature of the corner seal of the side exhaust port rises quicker than the peripheral exhaust port because it is exposed to the exhaust ports. In addition, lack of the oil film easily occurs when it passes the exhaust ports, which is unfavorable for the lubrication. In order to resolve these issues, two oil injection nozzles for the gas seal lubrication were fitted to the rotor housing to actively lubricate the rotor side faces. As shown in Fig.30, this improved lubrication of the corner seal, minimizing the amount of the lubrication oil. Fig.31 shows lubrication amount required for the each lubrication system.

SUMMARY

The new-generation high-performance RE named RENESIS has been developed. It incorporates innovative technologies like the side exhaust port and it has made a great progress compared to the previous RE with the peripheral exhaust port.

- 1.The side exhaust port enabled to drastically increase the areas of the intake and the exhaust ports, achieving 49% higher output compared to the previous peripheral exhaust port natural aspirated model, while still keeping zero overlap of the intake and exhaust overlap.
- 2.The use of the side exhaust port and the cut-off seal, etc reduced internal EGR and improved combustion at low speed and light load range, leading to the drastic improvement in the fuel economy performance.
- 3.The reduced emissions by the side exhaust port allowed the RX-8 to meet LEV-II.

4. Gas seals were redesigned for the side exhaust port RE. The life of gas seals are maintained at the same level as the previous model RE.

REFERENCES

1. Shimizu, R.; Tashima, S.; et al. "The Characteristics of Fuel Consumption and Exhaust Emissions of the Side Exhaust Port Rotary Engine" SAE 950454
2. Kinoshita, H.; Noguchi, N.; et al. "New Rotary Engine "RENESES" Mounted on RX-8" Mazda technical review No.21 Japan, 2003
3. Tashima, S.; Ebino, H.; et al. "Side Exhaust Port Rotary Engine Mazda technical review No.21" Japan, 2003
4. Tokuda, S.; Shimizu, R.; et al. "Emission Reduction Technology in Newly Developed RENESIS Mazda technical review No.21" Japan, 2003
5. Yamashita, O.; Watanabe, Y.; et al. "Rotary Feeling / "Fun to Drive" Mazda technical review No.21" Japan, 2003
6. Ueki, S.; Fuse, S.; et al. "Development of Lubrication Analysis for Gas-Seals of Rotary Engine" Mazda technical review No.15 Japan, 1997